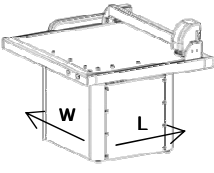
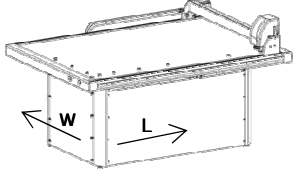

## GUNNAR AiOX

### OVERVIEW TECHNICAL DETAILS

Parameter	GUNNAR AiOX M	GUNNAR AiOX XL
		
Outer Dimensions L x W x H	130 x 160 x 121 cm   51 x 63 x 48"	210 x 160 x 121 cm   83 x 63 x 48"
Cutting Table Height	90 cm   36"	90 cm   36"
Max. Mat Board Sheet Size L x W	105 x 126 cm   41.3 x 49.6"	126 x 186 cm   49.6 x 73.2"
Max. Mat Board Thickness guaranteed	3.5 mm   0.14"	
Mat Board Fixation Series Models	Turnable Button Clamp System	
Machine Weight	140 kg   308 lbs	170 kg   375 lbs
Packaging Weight	40 kg   88 lbs	
Packaging Size L x W x H	168 x 142 x 85 cm   66 x 56 x 34"	225 x 164 x 85 cm   89 x 65 x 34"
Power Supply	230 V / 50 Hz / 6 A   115V / 60Hz / 10A	
Compressed Air Supply	Min 8 bar   Min 116 psi	
Cutter Operating Software	GMC 2.x or higher	
PC Interface	USB 2.0 or higher	
PC Operating System	Windows 7 or higher, 64bit	
PC Processor	Min 2GHz, Multi Core Processor	
PC Working Memory	Min 8GB RAM	

Functions	GUNNAR AiOX Basic	GUNNAR AiOX Hybrid	GUNNAR AiOX Professional
Cutting Head System	Single cutting head for 45° cuts	Integral Hybrid cutting head for 45° and 90° cuts	Fully synchronized double head system with two separate cutting heads for 45° and 90° cuts
45° Cut	X	X	X
90° Cut	-	X	X
Automatic change between 45° and 90° cut	-	X	X
Highly efficient and fast change between 45° and 90° cut	-	-	X
Automatic change of blade cut debt for V-grooves	X	X	X
Fully automatic, dynamic blade dept adaption for all mat board thicknesses	-	X	-
Complete mat board cut without any tool or head change	X	X	X
Max. Cutting Window Size l x w	M 87.5 x 121 cm   34.5 x 47.6" XL 121 x 169 cm   47.6 x 66.5"	M 87.5 x 121 cm   34.5 x 47.6" XL 121 x 169 cm   47.6 x 66.5"	M 87.5 x 114 cm   34.5 x 44.9" XL 114 x 169 cm   44.9 x 66.5" COE 114 x 163 cm   44.9 x 64"
Max. positioning speed	1'000 mm/s   40"/s	1'000 mm/s   40"/s	1'000 mm/s   40"/s
Max. cutting speed	600 mm/s   24"/s	600 mm/s   24"/s	800mm/s   32"/s
Warranty	50'000 openings or 2 years	50'000 openings or 2 years	400'000 openings or 2 years

Options	GUNNAR AiOX Basic	GUNNAR AiOX Hybrid	GUNNAR AiOX Professional
Vacuum table	X	X	X
Table mounting	X	X	X
Dual-Zone-Cutting, COE mode	-	-	X (only XL and only w/o vacuum)
T1 «engrave» Tool	X	X	X
T2 «scribe» Precision Pen Tool	X	X	X

Technical specifications may vary based on mat cutter options.